

## Cut Fast Holes • Cut Accurate Holes • Cut Smooth Holes

The Ultimate Portable Tool For Large Diameter Drilling In Metal

### Industries / Applications

- > Drill Steel, Stainless Steel, Tough Alloys, Aluminum, And Plastics Up To 3/16" Depth
- > For Convenient Use In Handheld Power Drills And Drill Presses
- > Mechanical, Electrical, Plumbing, Maintenance Repair Operations, Steel Fabrication, Construction, Automotive, Truck/Trailer, Agriculture

### Anatomy & Nomenclature

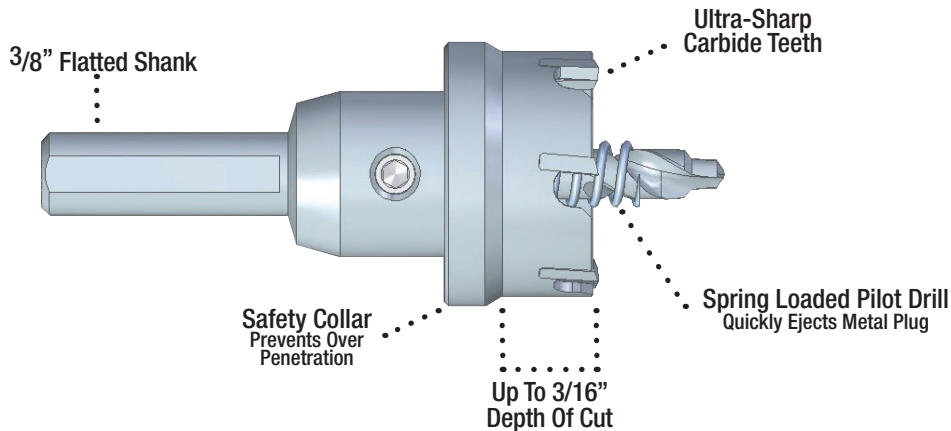

### Operating Guidelines

1. Start cutting with pilot drill to center location of the hole
  2. When pilot drill is close to breaking through material, ease up on feed pressure - this will minimize the impact of the carbide teeth when they meet the material being drilled and prevent tool breakage
  3. Drill large diameter hole using correct speeds and feeds
- > Use CT5 Cutters In Rotary Mode Only - Impact Mode Will Damage Cutter

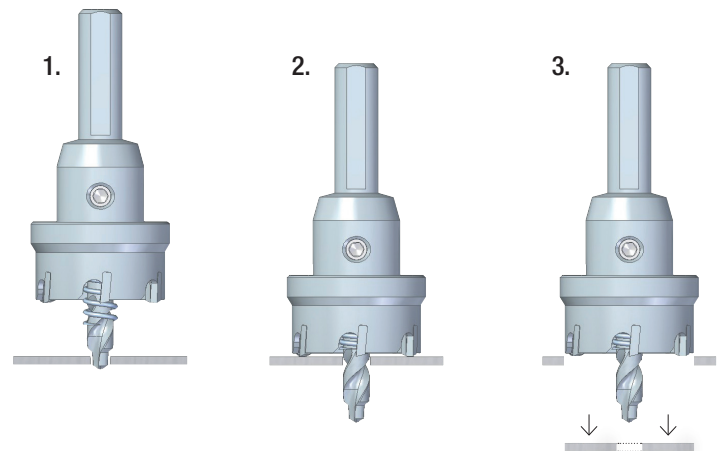

### Speed Recommendation (RPM)

SIZE	STEEL	STAINLESS STEEL
9/16 to 13/16	700 - 1000	300 - 700
7/8 to 1-3/16	500 - 800	200 - 450
1-1/4 to 1-9/16	300 - 600	175 - 315
1-5/8 to 2	200 - 500	120 - 225
2-1/16 to 2-3/8	200 - 400	95 - 195
2-7/16 to 3	150 - 300	80 - 150
3-1/16 to 5	100 - 200	60 - 120

### BruteLube Cutting Fluid & Wax

By Enhancing Tool Heat Resistance, Operators Will Experience Smoother Cuts, Longer Tool Life, And Increased Production

