

Project Name:	Type:
Part Number:	Date:

# DOUBLE ENDED BYPASS T8 8FT

## FEATURES

- Integral driver suitable for 120-277V
- Replaces 8ft F96T8 / F96T12 Fluorescent lamps
- Available in Single pin (Fa8) & Recessed Double Contact pin (R17d)
- Double ended installation, no need to change existing sockets
- Opaque glass design eliminates pixilation and reduces glare
- High performance, lumen output up to 5,500lm, 128LPW
- 310° wide light emitting area
- Suitable for enclosed fixtures
- UL 1598C classified
- Temperature rating: -4°F/20°C – 113°F/45°C
- Rated lifetime (L70): 50,000hrs
- 5 year limited warranty
- Suitable for all indoor general lighting applications and damp locations



## SPECIFICATIONS

Product	Model	Equiv.	Input Voltage	Wattage	Lumens	CCT	CRI	Efficacy (LPW)	Power Factor	THD	Beam Angle	Dim.	Fixture Rating	Cert.
34869	43T8/8F/840/DEB/Fa8	F96T8 F96T12	120-277V	43	5,500	4000K	82	128	0.9	<20%	160°	No	Enclosed	DLC
34870	43T8/8F/850/DEB/Fa8	F96T8 F96T12	120-277V	43	5,500	5000K	82	128	0.9	<20%	160°	No	Enclosed	DLC
34871	43T8/8F/840/DEB/R17d	F96T8 F96T12	120-277V	43	5,500	4000K	82	128	0.9	<20%	160°	No	Enclosed	-
34872	43T8/8F/850/DEB/R17d	F96T8 F96T12	120-277V	43	5,500	5000K	82	128	0.9	<20%	160°	No	Enclosed	-

## DIMENSION & WEIGHT

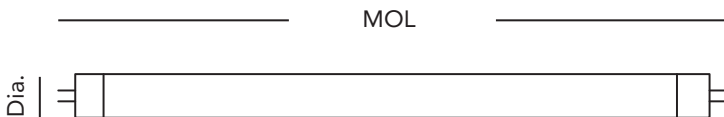

Model	43T8/8F/xxx/DEB/Fa8	43T8/8F/xxx/DEB/R17d
Base	Fa8 (Single Pin)	R17d (Recessed Double Contact)
MOL	93.9"	93.9"
Dia.	1.09"	1.09"
Weight	0.92lb	0.92lb

Where xxx means 824-965 which indicates CRI and color temperature



# DOUBLE ENDED BYPASS T8 8FT

## INSTALLTION

### Fa8 - SINGLE PIN 1 LAMP

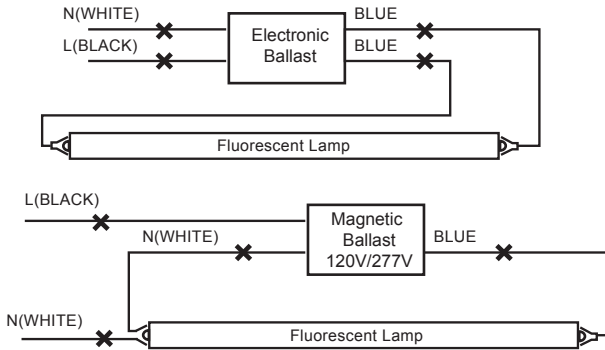

**Step 1.** Cut all wires connected to the existing ballast, remove the ballast

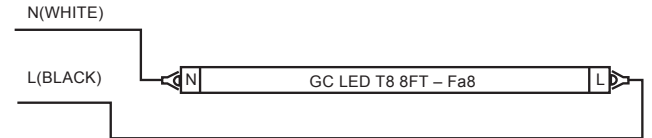

**Step 2.** Wire the holders and lamps according to the above diagram

### PIN R17d – Recessed Double Contact 1 LAMP

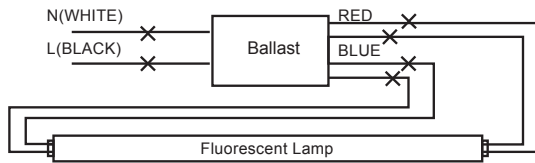

**Step 1.** Cut all wires connected to the existing ballast, remove the ballast

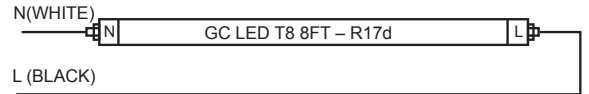

**Step 2.** Wire the holders and lamps according to the above diagram

## ACCESSORY ORDERING INFORMATION

Product	Model	Description	Picture	Dimension	Weight
34873	T8CLIP	Clip kit to fix the 8ft tube (Clip x 1, ST4.2 hexagon washer head self drilling screw x 1)			0.2oz
98235	50EMINVERTER	Emergency Inverter 50W			9.0lb

### 50EMINVERTER

- Fixtures must be installed within 250' of inverter
- UL 924 listed for field installation
- Suitable for damp locations
- Galvanized steel enclosure with 36" conduit for wiring connections to the fixture
- Includes test switch and charge indicator accessory kit
- Replaceable and recyclable long-life high temperature nickel-cadmium battery